

Operating Instructions

1. **Intended use.** This Power Tool is intended for industrial applications, for cutting sheet metal (maximum capacity is indicated in the Specifications), for use with cutting jaws and cutting blades which are indicated in these operating instructions or recommended by DRÄCO

2. Initial Operation

Observe the rated voltage: The voltage of the power source must match that given on the nameplate of the machine. Machines for 230V can also be operated on 220 V power sources.

Switching ON and OFF

Switching ON: Slide the switch pad (109) forward

Switching OFF: Slide the switch pad (109) to the rear.

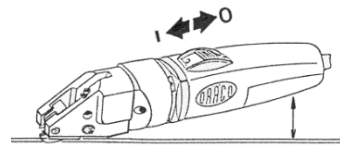

2. **The material to be cut must always be free of oil or grease.** Always place the machines jaws flat on the work piece.

3. **Cut-outs:** Drill a starting hole with a 12-14 mm diameter drill. **Circular cuts:** Always cut counter clockwise and from left to right.

4. Do NOT cut sheet metal along welding points. Do NOT cut multi-layer sheets, which exceed the maximum cutting capacity.

Environmental protection



Recycling raw materials instead of waste disposal. Machine, accessories, and packaging should be sorted for environment-friendly recycling. These instructions are printed on recycling paper manufactured without chlorine

Care and Maintenance



Before working on machine disconnect from power supply by removing plug from socket. Always keep the machine and the ventilation slots clean. Oil the knife pin and knife at regular intervals. If the machine should happen to fail despite the care taken in manufacture and testing, repair should be carried out by an authorised customer services agent for DRÄCO power tools

CE-Declaration of conformity

We declare under our sole responsibility that this product is in conformity with the following standards.

2006/42/EG, 2014/30/EU, EN 60745-2-8:2009, EN ISO 11688-1:2009, EN ISO 12100:2010

CE 2016 Susanne Draenert

5. For inside cutting, the shortest curve possible has a radius of 200 mm ($\pm 8^\circ$). If cutting a radius with the right hand, cut from right to left. The outside radius is unlimited.

6. For **cutting out** curved or circular inside patterns, a 14 mm ($\pm 1/2$ ") hole, or a punched slot should be made to insert the centre cutter.

7. If after cutting, a **small strip** remains this can easily be trimmed off to the exact measurement, without leaving a burr or any distortion of the material. Just one side of the power tools can be used for cutting also (e.g. along a marked line). Lift the power tools out of the shavings while the motor is running. Cut off longer shavings.

8. Both knife and jaws can be sharpened. After being sharpened or replaced, the knife at its lowest point should protrude the jaws by approximately 3 mm. The knife should have approximately 0,05 mm (0,005") play on each side of the jaws, centring the cutter with spacing shims supplied.

9. Every 200 operating ours have the cutting blade and cutting jaws sharpened at a specialist workshop.

10. **Ensure that the material to be cut is free of oil and grease.**

Noise/vibration information

Measured values determined according to EN 50 144.

Typically, the A-weighted sound pressure level of the tool is 83 dB(A). The noise level when working can exceed 85 db (A).

Wear ear protection!

The typical hand-arm vibration is below 7,5 m/s²

Warranty

DRÄCO tools carry a guarantee of 12 months from date of delivery.

Damage attributable to normal wear and tear, overload or improper handling will be excluded from the guarantee. (e.g. blades/knives and jaws)

In case of complaint please send the machine, **undismantled**, to your dealer or the DRÄCO Service Centre for electric power tools.



Operating Instructions for the metal shear 1020-1

To avoid any disturbance please read the following instructions:

For your safety:



1 Safe operation of this machine is possible only when the operating instructions and the safety precautions are read completely and the instructions contained therein are strictly observed.

2 The machine must not be used when damp and must not be operated in a wet environment.

3 Always inspect cable and plug before using machine. Only have damage repaired by a qualified professional. Put the plug into the mains socket only when the machine is switched off.

4+5 Always wears protective goggles, protective gloves and heavy-duty shoes when working.

- Do not carry the machine by the cable.
- Always remove the plug from the power supply socket before carrying out any work on the machine, when interrupting work and when not using the machine.
- Always place the cable to the rear away from the machine.
- Apply the machine to the sheet metal only when switched on.
- Always provide for secure footing when working.
- Firmly clamp the workpiece if it does not remain stationary from its own weight.
- The knife should not rub on the jaws: Possible danger of cutting tool breakage.
- Do not exceed the maximum allowable material thickness especially when cutting over doublers, folded joints or welded seams.

For further notes on safety refer to enclosed sheet

DRÄCO metal shears			1020-1
max. cutting capacity	Art.nr.		61040-1
steel	400 N/mm ²	mm	2,0
stainless steel	600 N/mm ²	mm	1,5
stainless steel	800 N/mm ²	mm	1,3
aluminium	250 N/mm ²	mm	3,0
tightest radius		mm	200
working speed		m/min	5
strokes		min ⁻¹	2200
motor capacity		Watt	500
weight		kg	1,8

1020-1 spare parts		
knife	010135E	
set of jaws	BG35146	
knife-pin set	BG35155	
optional accessories		
metal-box		18000
adjustable guide S/01	up to 100 mm	10059
adjustable guide S/01	up to 250 mm	10060
adjustable guide S/01	up to 500 mm	10061
support roller	metal	10077

Exploded view DRÄCO Metal Shear 1020-1

13.12.2022

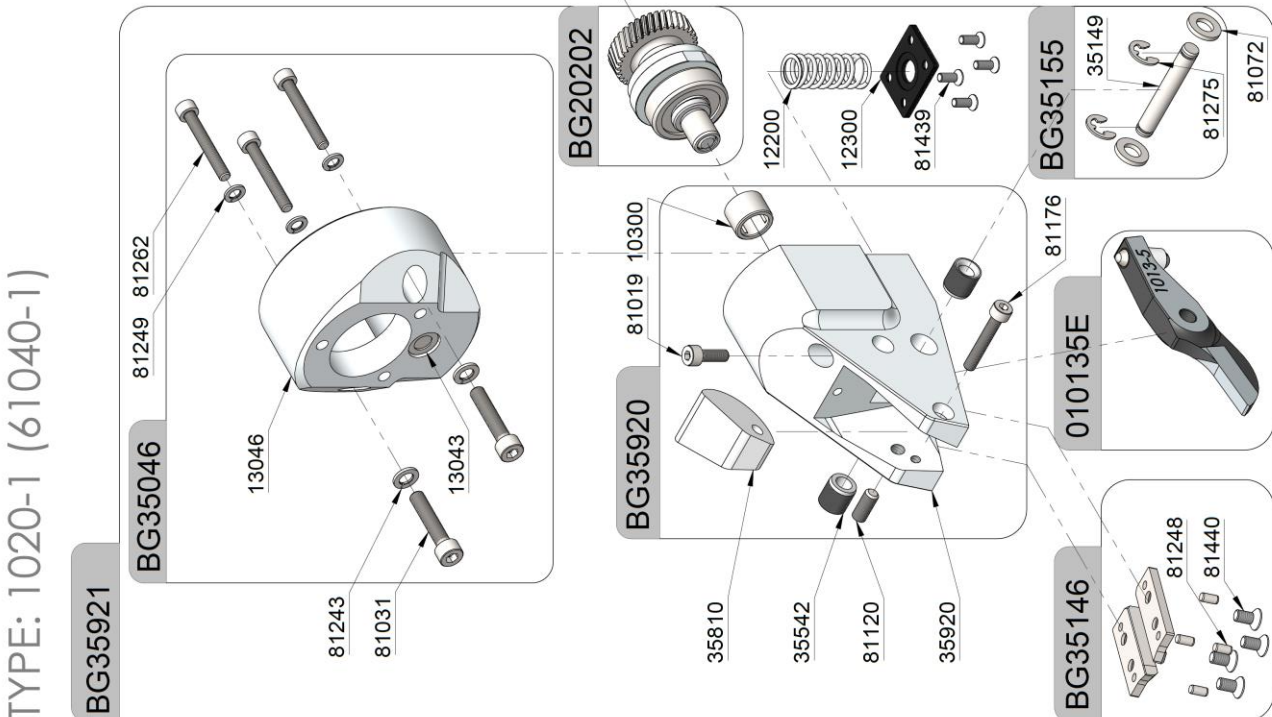
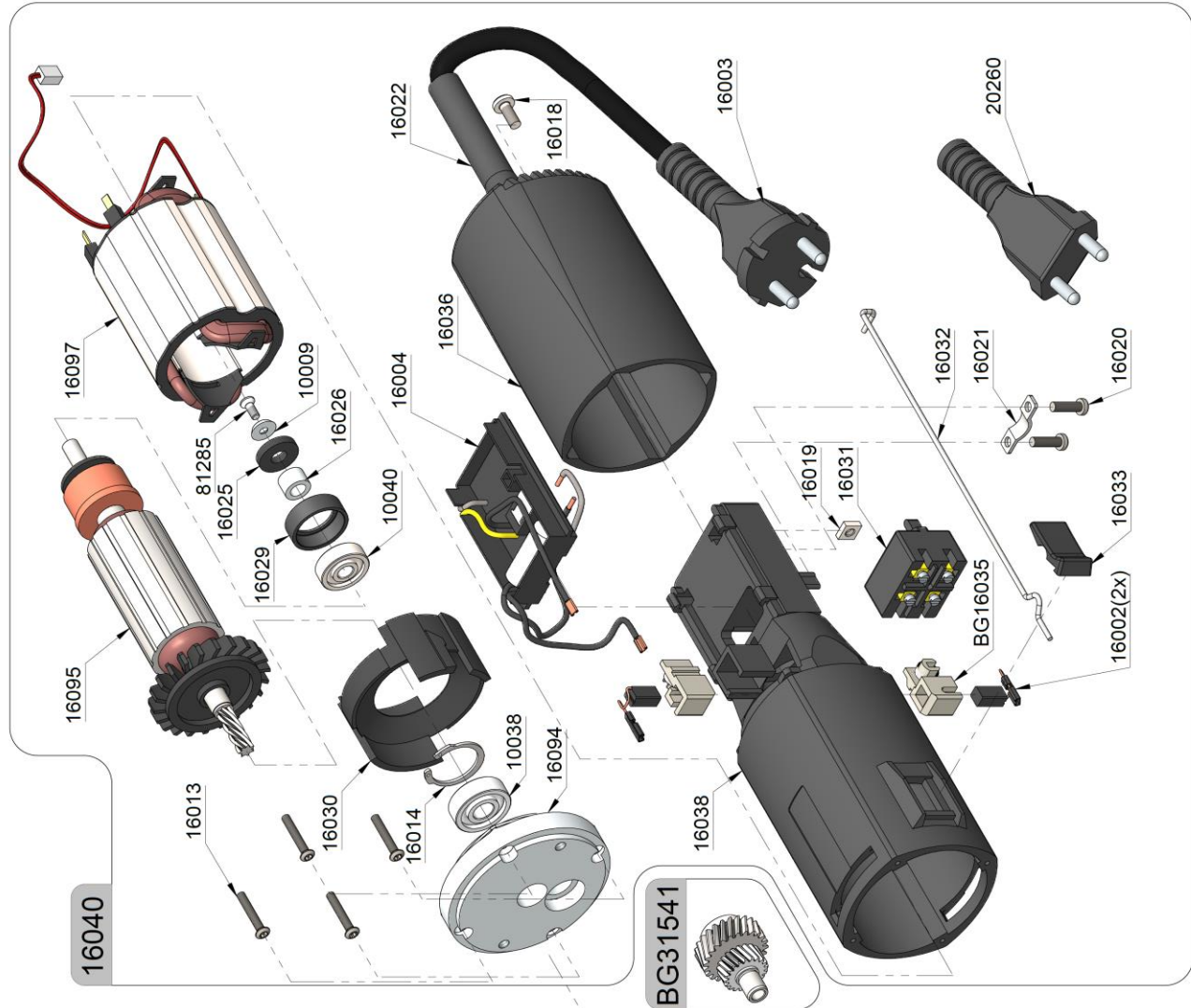

TYPE: 1020-1 (61040-1)

SERVICE TIPS

Before working on machine disconnect from power supply by removing plug from socket. Wear protective glasses!

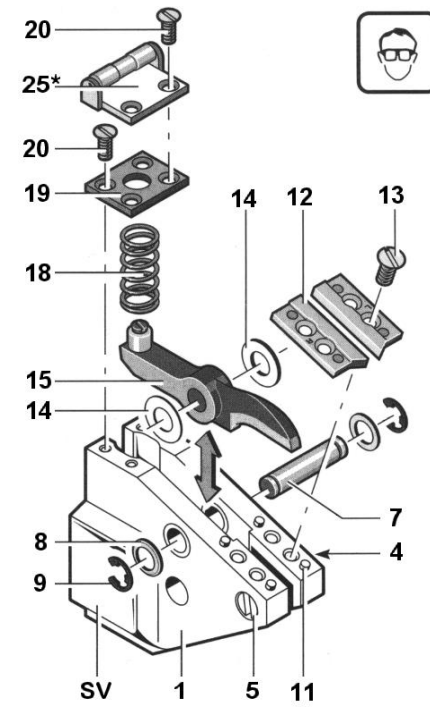

Replacing/Adjusting the Knife

Clamp the machine in a vice on the clamping surfaces SV between aluminium protective jaws.

Unscrew the screws 20 and remove the spring plate 19. Remove the spring 18. Remove the Cotter Pin 9 and the Washer 8. Push back the knife pin 7. **⚠ Do NOT interchange the Spacing Shims 14: the wrong spacing could ruin the jaws and knife.** Insert a new knife with the old spacing Shims 14. Insert the knife pin. Mount the washer 8 and the Cotter Pin 9. Insert the spring 18. Reassemble spring plate 19.

Replacing the Jaws

Loosen the screws 13 and remove the jaws 12. Press out the positioning pins 11. Mount new jaws and positioning pins. Tighten the screws 13.

Adjusting the knife Clearance

For clearance between knife and jaws that is too large, loosen the fillister head screw 5. Adjust the clearance with the setscrew 4. Retighten the fillister head screw 5.

⚠ The knife must not rub on the jaws: Danger of breakage.
Note: If heavy burring is produced while cutting, repeat the adjustment.

Sharpening the Knife/Jaws

The Knife and the Jaws must be sharpened and adjusted at the same time. This work should be performed by an authorised DRÄCO customer service location. Send in the complete machine for this purpose.

*Position numbers used are valid
← for exploded view (knife mounting) only.*

Max Draenert GmbH & Co.KG Electric - Cordless - Pneumatic Tools - Machines Germany

Factory I: Administration D-73777 Deizisau P.O.Box 1120 Phone ☎ +49-7153-8217-0
Manufacturing Shears D-73779 Deizisau Gutenbergstrasse 15-17 Fax 📠 +49-7153-8217-66

Internet <http://www.dracotools.com>

e-mail: ✉ draenert@dracotools.com

Your dealer: