

## Instructions

The pos. number used are in connection with the opposite Service-tips

1. Before using the metalshears please check cutting capacity see technical data. For cutting spiral pipes through a seam, it is possible, when using model number 18/3514-2. (4 x 0,90 mm).
2. Always place the machine straight on the work piece. The jaws (pos. 10) must lay flat on the material. When cutting sheet metal etc. do not oil cutting surface.

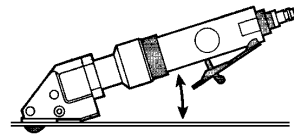

3. When cutting a slot without drilling an end hole, pull shear backwards with motor running.
4. **Circular cuts:** Always cut counter clockwise from right to left, this enables a shorter inside curve.

### Equipment protection

The maximum allowable operating pressure of 6.6 bar must not be exceeded; use a pressure reducer if necessary.

To avoid damage by contaminated pressurised air, a maintenance unit must be used in the air supply system.

The maintenance unit consists of three main components:

- Filter with water separator
- Pressure reducer with manometer

Mist oilier for lubricating the machine with SAE 20 or SAE 10 motor oil.

**Do not use petroleum or diesel oil.**

### Care and Maintenance

**Before carrying out any work on the tool itself, disconnect the air supply.**

Oil the knife pin 18 and knife 11 at regular intervals.

Should the tool fail in spite of careful manufacturing and testing procedures, the repair is to be performed by an authorised customer service location for pneumatic or electric tools.

### CE Declaration of conformity

We declare under our sole responsibility that this product is in conformity with the following standards or standardisation documents:

EN 792-13, ISO 8662-1, EN50144, according to the provisions of the regulations 89/37.

CE 09 Max Draenert

5. For cutting out curved or square inside patterns a hole between 10 - 14 mm should be drilled to insert the cutting knife. For square cut outs drill a hole in each corner.
6. If after cutting, a small strip remains, this can be trimmed off to the exact marked line, without leaving a burr or any distortion of the material.
7. When producing the same parts several times a template can be used. The knife will follow the template on the side. A marked line can be easily followed due to the points on the jaws.
8. Both knife and jaws can be resharpened. After being resharpened or replaced, the knife should be adjusted at it's lowest point and should protrude the jaws by approximately 2.5 mm.
9. If following these instructions, you are able to work with the knife and jaws about 200 working hours depending on the hardness of the materials.

**ATTENTION : THE MATERIAL MUST ALWAYS BE FREE OF GREASE OR OIL.**

### Noise/vibration information

Measured values determined according to EN 792, PNEUROP PN8NTC1, ISO 3744, ISO 8662/1.

Typically the A-weighted noise levels of the tool are: Sound pressure level: 78,2 dB (A); Sound power level: 78,9 dB (A)

Wear ear protection!

The typical hand-arm vibration is below 2,5 m/s<sup>2</sup>.

### Guarantee

Dräco tools carry a guarantee of 6 months from date of delivery.

Damage attributable to normal wear and tear, overload or improper handling will be excluded from the guarantee.

In case of complaint please send the machine, to your dealer or the Dräco Service Centre for electric power tools.

### Environmental protection



**Recycling raw materials instead of waste disposal**

Machine, accessories and packaging should be sorted for environment-friendly recycling.

These instructions are printed on recycled paper manufactured with chlorine.



## Instructions Pneumatic Sheet Metal Shears 1910, 1913 & 1920

To avoid failure, when using DRÄCO – Metal Shears, please read these instructions

**For your safety:**



**1 Safe operation of this machine is possible only when the operating instructions and the safety precautions are read completely and the instructions contained therein are strictly observed.**

- Apply the machine to the sheet metal only when switched on.

- Always provide for secure footing when working.

- Firmly clamp the work piece if it does not remain stationary from its own weight.

- The knife should not rub on the jaws: Possible danger of cutting tool breakage.

- Do not exceed the maximum allowable material thickness especially when cutting over doubles, folded joints or welded seams.

**2** Use ear protectors and protective goggles.

**3** Wear protective gloves and sturdy footwear.

- Before carrying out any work on the tool itself, during pauses in the work and when not in use, disconnect the air supply.

☞ **For further notes on safety refer to enclosed sheet**

### Technical Data:

DRÄCO Metal Shears	type	1910	1913	1920
<b>max. cutting capacity</b>	Art.no.:	62030-1	62040-1	62050-1
steel	mm/ga. mm	<b>1,0</b>	<b>1,3</b>	<b>2,0</b>
stainl. steel	mm/ga. mm	<b>0,7</b>	<b>1,0</b>	<b>1,5</b>
stainl. steel	mm/ga. mm	<b>0,4</b>	<b>0,7</b>	<b>1,3</b>
aluminium	mm/ga. mm	<b>1,5</b>	<b>2,0</b>	<b>3,0</b>
tightest radius	mm/ "	<b>50</b>	<b>100</b>	<b>200</b>
working speed	m/min	<b>9</b>	<b>9</b>	<b>9</b>
strokes	min <sup>-1</sup>	<b>3000</b>	<b>3000</b>	<b>3000</b>
air-consumption at 6 bar/min.	m <sup>3</sup> ±	<b>0,18</b>	<b>0,18</b>	<b>0,18</b>
motor capacity	watts	<b>200</b>	<b>200</b>	<b>200</b>
weight	kg	<b>1,3</b>	<b>1,3</b>	<b>1,3</b>
noise	dB(A)	<b>78,2</b>	<b>78,2</b>	<b>78,2</b>

Spare parts	1910	1913	1920
knife	01011	01001	010135E
set of jaws	BG13574/1	BG10600	BG13574
knife-pin set	BG12555	BG12555	BG12555

### Optional accessories

adjustable guide S/01	up to 100 mm	10059
adjustable guide S/01	up to 250 mm	10060
adjustable guide S/01	up to 500 mm	10061
support roller (plastic)		10076
support roller (metal)		10077

## Spare parts DRÄCO Pneumatic Metal Shears 1910, 1913 & 1920

TYPE: 1920 (62050-1)



To see the exploded view of the motor please follow the link:

[https://www.dracotools.com/uploads/download/s/downloads\\_download/od19\\_2.pdf](https://www.dracotools.com/uploads/download/s/downloads_download/od19_2.pdf)



## SERVICE-TIPS (Dismantling/assembling Knife)

Before performing any work on machine itself, disconnect the air supply. Clamp the machine in a vice on the clamping surfaces (SV) between aluminium protective jaws.

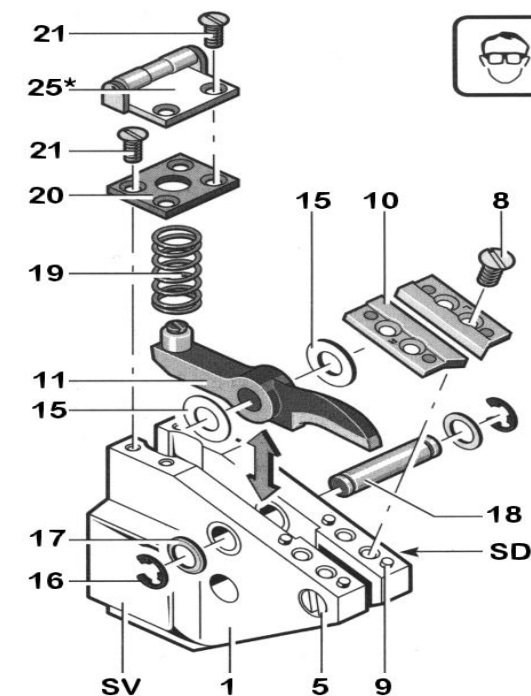

- Before replacing the knife, place a drop of oil on the right and left side between the housing (1) and the knife (11).
- Unscrew the screws (21) and remove the spring plate (20). Remove the spring (19).
- Remove the Circlip ring (16) and screw (17).
- Push the knife pin back (18).
- Lift the knife (11) and remove to the front.

- Do not interchange the spacers (15): The jaws and knife could be ruined by the wrong spacing.**
- Insert a new knife with the spacers (15). Insert the knife pin (18). Mount the washer (17) and the Circlip ring (16)
- Insert the spring (19). Remount the spring plate (20).

### Replacing the Jaws

Loosen the screws (8) and remove the jaws (10). Press out the positioning pins (9). Mount new jaws and position pins again. Tighten the screws (8)

**The knife (11) must not rub against the jaws (10): Danger of breakage.**  
Note: If heavy burring is produced while cutting, repeat the adjustment.

### Sharpening the Knife/Jaws

The knife and the jaws can be sharpened and must be adjusted after resharpening or replacing. This work should be performed by an authorised Dräco customer service location. Send in the complete machine for this purpose.

No warranty on knives and jaws.

The pos. numbers used on the service tips are in connection with the first page.

## Spare parts list DRÄCO Pneumatic Metal Shears 1910, 1913 & 1920

The pos. numbers used, are in connection with the opposite spare parts list.

Pos. no.	Order no.	Description	Quantity per shear	Pos. no.	Order no.	Description	Quantity per shear
1-43	BG10911	Shear Head 1910	1	44	10071	Flange	1
1-43	BG10912	Shear Head 1913	1	46	81280	Tap screw	1
1-433	BG10926	Shear Head 1920	1	47	81278	Tap screw	3
1	BG10910	Head Casting (pos.3,4-6,24,35)	1	48	81263	Hex. socket screw	3
				52	10072	Coupling Motor	1
3	81019	Screw	1	53	19053	Head Housing Motor Side	1
4	81120	Tap screw	1	54	19054	Nut	1
5	81272	Hex. socket screw	1	55	19055	Ball bearing	1
6	10810	Spacing block	1	56	19056	Ball bearing	1
8	81440	Flat head screw	4	57	19057	Gear holder	1
9	81248	Pin	4	58	19058	Cyl. Pin	3
				59	19059	Needle bearing	3
				60	19060	Gear	3
				61	19061	Gear housing	1
11-13	01011	Knife SD5 up 1 mm in thickness	1	62	19062	Washer	1
8-10	BG13574/1	Set of jaws 1910	1	63	19063	Ball bearing	1
				64	19064	Front cover	1
11-13	01001	Knife 1001 up to 1,3 mm in thickness	1	65	19065	Pin	3
8-10	BG10600	Set of jaws 1913	1	66	19066	Rotor	1
				67	19067	Vane	5
11-13	010135E	Knife 10135 up to 2 mm in thickness	1	68	19068	Cylinder	1
8-10	BG13574	Set of jaws 1920	1	69	19065	Cyl. Pin	3
				70	19070	Back rotor cover	1
13-14	35566	Knife adjusting screw with lockring	1	71	19071	Ball bearing	1
15	BG12400	Spacing shims set	1	72	19072	Valve screw cover	1
16	81275	Cir clip	2	73	19073	O-Ring	1
17	81072	Washer	2	74	19074	O-Ring	1
16-18	12500	Knife pin	1	75	19075	Regulator control	1
15-18	BG12555	Knife pin set	1	76	19076	Valve spring	1
19	12200	Spring	1	77	19077	O-Ring	1
20	12300	Spring cover	1	78	19078	Valve nut	1
21	81271	Flat head screw	4	79	19079	O-Ring	1
24	17900	Bushing	2	80	19080	Motor housing	1
(24)	17911	Bushing	2	81	19081	End adapter	1
25	BG10076	Support roller	1	82	19082	Air connector	1
35	10300	Needle bearing	1	83	19083	Valve bushing	1
29-39	10058	Complete drive	1	84	19084	Wrench	1
29	10005	Sleeve	1	85	19085	Safety lever	1
32	BG10004	Eccentric drive shaft Set (32-34,37)	1	86	19086	Spring	1
33	10250	Ball bearing	1	87	19087	Lever	1
34	10005	Sleeve	1	88	19088	Doval pin	1
35	10300	Needle bearing	1	89	19089	Rivit	1
36	10450	Cap for needle bearing	1	90	19090	Air exhaust tube	1
37	10006	Key	1	91	19091	Plug-in connector	1
38	10070	Coupling shear	1				

When ordering spare parts, please state position and order numbers.

Max Draenert GmbH & Co.KG Electric - Cordless - Pneumatic Tools - Machines Germany

Factory I: Administration D-73777 Deizisau P.O.Box 1120 Phone +49-7153-8217-0  
Manufacturing Shears D-73779 Deizisau Gutenbergstreet 15-17 Fax +49-7153-8217-66

Internet <http://www.dracotools.com>

E-mail: [draenert@dracotools.com](mailto:draenert@dracotools.com)