

Maintenance

All parts of the hand seamer are standardized, exchangeable, made of rustproof materials and thus largely maintenance-free. The two side guides (pos. 2 + 3, see previous page) should be lubricated with grease periodically.

Additional Dräco Hand Seamers



Hand Seamer for Standing Seam, K8:
closes pre-profiled panels in one operation into a standing seam and a tight joint.

Item.no.	91520
Closing length	210 mm
Length	255 mm
Width	270-570 mm
Weight	2,3 kg



Hand Seamer for Double Lock, K7-1:
closes the pre-closed standing seam in one operation into a double lock seam.

Item.no.	91515-1
Closing length	210 mm
Length	310 mm
Width	320-610 mm
Weight	3,3 kg



Read, observe and follow this manual and the other applicable documents, especially all safety instructions and warnings.



Always wear protective gloves!

Batten Hand Seamer K6-1

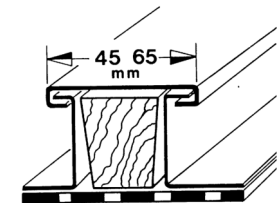

Item no.:	Closing length	Length	Batten cap width	Weight
91510-1	180 mm	250 mm	45-65 mm	3 kg

Manual

Tool elements

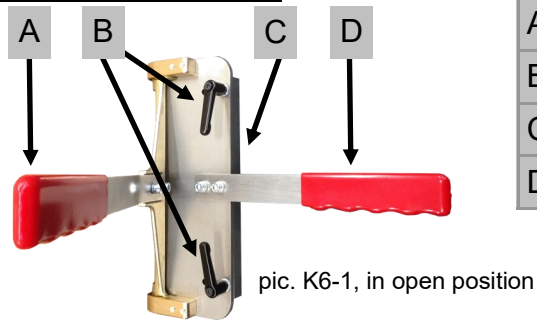

A	Closing handle
B	Adjustment lever
C	Stopper
D	Apply handle

Intended use

Only use batten seam locker K6-1 to close pre-profiled batten caps in the material thicknesses mentioned below.

Max. thickness of materials

Copper / Zinc / Aluminium	until 0,80 mm
Steel	until 0,80 mm
Stainless steel	until 0,50 mm

Operation method

- Adjust the K6-1 to the width of the cap using the adjustment lever (B) and stopper (C).
- Now place the K6-1 in open position (closing handle (A) vertical) on the cap, with the stopper (C) close to opposite side.
- Push the closing handle (A) down, while counter-pressing the apply handle (D), the batten seam is now closed.
- Open the closing handle (A) again and move the K6-1 by approx. $\frac{3}{4}$ of the tool length and repeat the locking process.

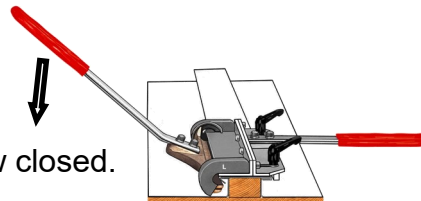

Spare parts

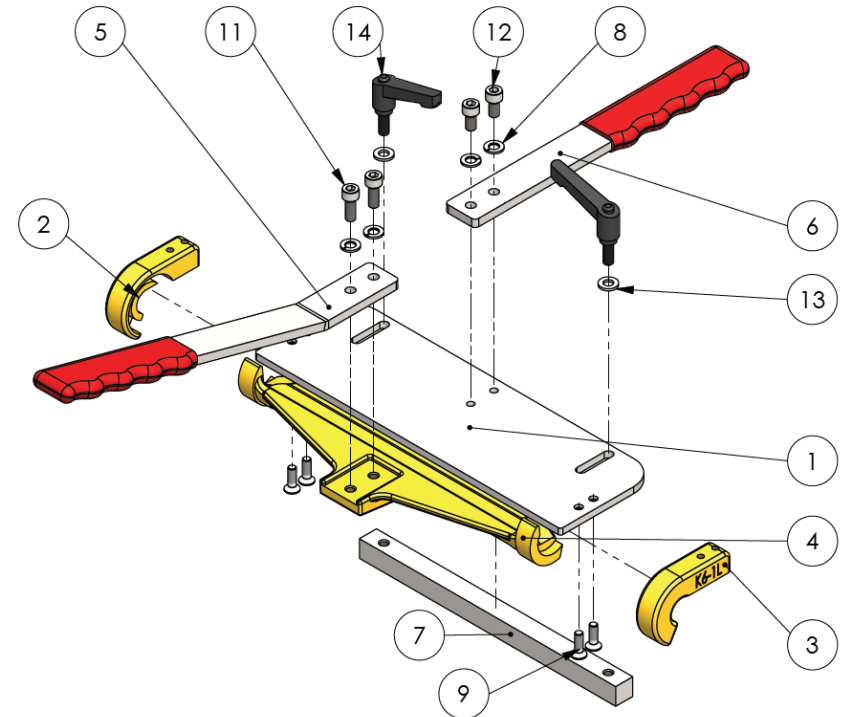

Pos.	Description	Pc.	Item no.
1	Rest plate	1	KH70069
2	Side guide right	1	KH70030-1
3	Side guide left	1	KH70029-1
4	Closing pivot	1	KH70012
5	Closing handle	1	BGKH70015
6	Apply handle	1	BGKH70014
7	Stopper	1	KH70027
8	Spring washer	4	81224
9	Flat-head screw	4	81226
11	Cylinder head screw	2	81195
12	Cylinder head screw	2	81183
13	Washer	2	81072
14	Adjustment lever	2	KH70028