



# Profile Metal Shear 3520

## General specifications:

- cuts without distortion or straightening of formed parts
- burr free cutting
- no finishing of the edges is required
- accurate cutting along a marked line
- single-side trimming is possible.
- working speed up to max. 5 m./min.
- clear view to scribed line or template
- long life tool
- easy, one hand, operation
- simple and safe to use
- can cause no injury while in motion
- noise under limit regulations
- almost no maintenance necessary
- knife and jaws regrind able
- parts are standardised and interchangeable

- shear ideal for all installation shops, examples: cable trays, coated cable trays, cable ladders, spiral tubing, mesh and wire
- the metal-shear for U-C-L profiles up to 2 mm
- new 500 watt motor
- bend folded cable trays cutting in one operation.
- even cutting of **stainless steel** cable trays without any problems (up to 1,5 mm / 18 ga.)
- optional knife serrated for coated materials.
- mitring cuts of cable trays possible

## ideal for:

- shop installation
- for heating and ventilating
- ventilation system fabrication, partitions
- construction-plants, etc.

## also available:

- pneumatic: type 18/3520
- 12 Volt cordless tool: type AK 3520

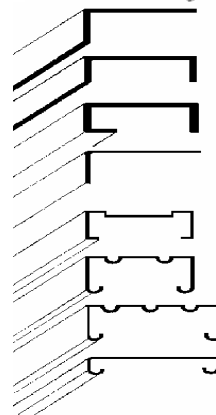
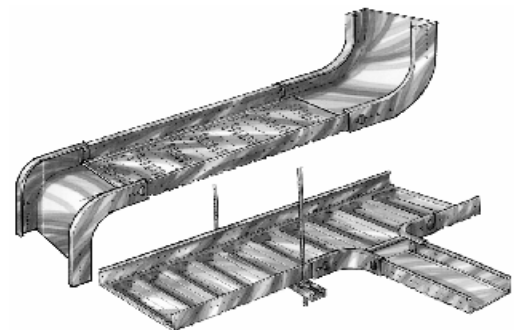

cutting of shaped parts



Gold Medal Bavarian State Prize 1999

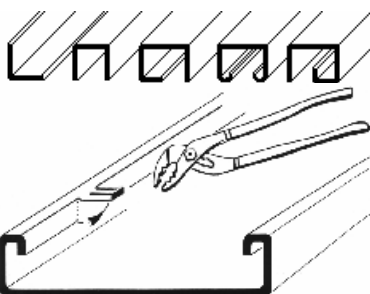

some profiles need lifting up at the side with a pair of pliers

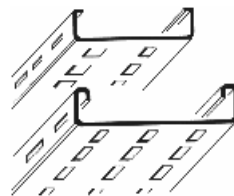

DRACO Profile Metal Shear		type	3520
<b>max. cutting capacity</b>		Art.no.	61060
steel	400 N/mm <sup>2</sup>	mm/ga.	<b>2,0 / 14</b>
stainless steel	600 N/mm <sup>2</sup>	mm/ga.	<b>1,5 / 16</b>
stainless steel	800 N/mm <sup>2</sup>	mm/ga.	<b>1,3 / 18</b>
aluminium	250 N/mm <sup>2</sup>	mm/ga.	<b>3,0 / 10</b>
tightest radius		mm/inch	<b>200 / 8</b>
working speed ±		m/min	<b>5-7</b>
strokes		min <sup>-1</sup>	<b>2400</b>
motor capacity		Watts	<b>500</b>
weight		kg	<b>2</b>

3520 spare parts	
Knife heavy duty	035201
set of jaws	BG35020
knife-pin set	BG35055
optional accessories	
metal-box	18000
zigzag knife	03527
support roller (metal)	BG10077

all units are ready to use

BG=Set

other voltages available